

## ALUMIL M9800 Accordion

***Product line for accordion doors, distinguished by its low accessories' cost and its fast and easy fabrication methodology.***

Basic characteristics:

- ✓ 50 mm sash width
- ✓ Combination of teflon sliding roller and sash-connecting hinge into a single accessory, able to support 250 Kg (125 Kg per sash)
- ✓ Sealing with both EPDM gaskets and high-density brushes
- ✓ Low threshold for comfortable access and passage
- ✓ Availability of locking door construction, opening inwards or outwards
- ✓ Supports constructions with theoretically infinite sashes, surpassing restrictions that were present in accordion doors with traditional external mechanisms (i.e short external guides, substantial cost increase for every extra sash, etc)
- ✓ Includes special leveling profiles, which adjust the construction to the walls' slope
- ✓ Supports single, double or triple glazing, from 24 up to 32 mm

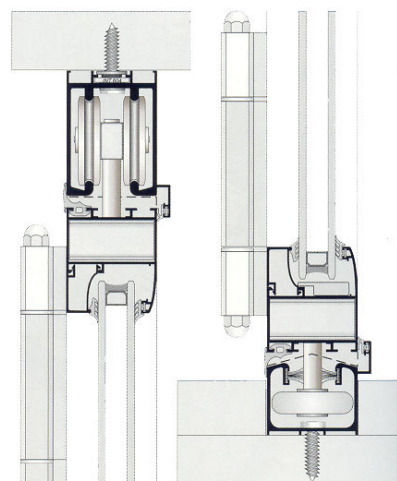

TECHNICAL SPECIFICATIONS OF PROFILES	
Aluminum alloy	AlMgSi (EN AW 6060)
Hardness	12 Webster or 70 HB minimum
Minimum Powder Coating Thickness	75µm minimum
Profile thickness (min-max)	1,4 – 1,8 mm
Profile Geometry Control	EN DIN 12020-2 Compliant

TECHNICAL SPECIFICATIONS OF SYSTEM TYPOLOGIES	
Sash width	50 mm
Glazing supported	Single, double or triple, from 24 up to 32 mm
Maximum glazing weight	250 Kg per roller (-hinge) thus 125 Kg per sash
Sealing	Two level sealing, using two rows of EPDM gaskets and/or high-density brushes

Construction options:

- ✓ Accordion doors, starting from at least three, and ending to a theoretically infinite number of sashes
- ✓ Option of both symmetrical and asymmetrical construction, limited only by an odd number of sashes in each folding side
- ✓ Option of installing “tilt-and-turn” sashes on the folding ones
- ✓ Availability of constructing sash partitions, using a “T” profile in the folding sashes
- ✓ Availability of shutter construction

Certifications:

- ✓ The design, the production process, and the quality control of all profiles produced by Alumil are certified with ISO 9001.
- ✓ The process of electrostatic powder coating is certified by QUALICOAT and RAL (GSB) in all plants operated by Alumil.